

MAXIM

MAX3902 Evaluation Kit

Evaluates: MAX3902

General Description

The MAX3902 evaluation kit (EV-kit) provides electrical evaluation of the MAX3902 receiver. The EV-kit also includes an optical section where a photodiode can be installed and optical evaluation is possible.

Component List

DESIGNATION	QTY	DESCRIPTION
C1	1	0.01 μ F \pm 10% Ceramic Capacitor (0402)
C2	1	0.022 μ F \pm 10% Ceramic Capacitor (0402)
C4, C5, C10, C14, C16, C17, C33, C34, C39	9	0.1 μ F \pm 10% Ceramic Capacitors (0402)
C6, C35	2	10pF \pm 10% Ceramic Capacitors (0402)
C15	1	10 μ F \pm 5% Tantalum Capacitor (B Case)
C28	1	2pF \pm 10% Ceramic Capacitor (0402)
C29	1	Open
J1-J3, J15, J16, J18	6	SMA connectors (edge-mount, tab contact)
J6, J10, TP3, TP7, TP13	5	Test Points
JU1, JU4, JU5	3	2-pin headers, 0.1in centers
L2	1	1 μ H \pm 5% inductor (1008CS)
R1	1	100k Ω \pm 5% resistor (0603)
R2	1	1.5k Ω \pm 5% resistor (0603)
R3	1	3.01k Ω \pm 5% resistor (0603)
R4, R5	2	2.37k Ω \pm 5% resistors (0603)
R6	1	49.9k Ω \pm 5% resistor (0603)
R11	1	511 Ω \pm 5% resistor (0603)
R22	1	10k Ω \pm 5% resistor (0603)
R23	1	0 Ω \pm 5% resistor (0402)
U1, U2	2	MAX3902 die in QFN24
None	3	Shunts
None	1	MAX3902 EV board

Ordering Information

PART	TEMP. RANGE	IC PACKAGE
MAX3902EVKIT	-40°C to +125°C	24QFN

Features

- ◆ Easy +3.3V Power Supply Operation
- ◆ Fully Assembled and Tested
- ◆ Optical Evaluation Possible

Component Suppliers

SUPPLIER	PHONE	FAX
AVX	843-444-2863	843-626-3123
Coilcraft	847-639-6400	847-639-1469
Digi-Key	218-681-6674	218-681-3380
EF Johnson	402-474-4800	402-474-4858
Murata	415-964-6321	415-964-8165

Note: Please indicate that you are using the MAX3902 when ordering from these suppliers.

Quick Start

Electrical Evaluation

- 1) Install a shunt across JU4. Remove shunts from JU1 and JU5.
- 2) Connect a +3.3V power supply to J6. Connect ground to J10.
- 3) Connect a DC current source to J18 and adjust the input current to 220 μ A.
- 4) Connect a data signal to J1 (IN) with a 2V_{P-P} amplitude. This will create a 444 μ A_{P-P} input current.
- 5) Connect J2 and J3 to a high-speed 50 Ω oscilloscope. The output seen on the oscilloscope should be an 800mV_{P-P} differential output.

Optical Evaluation

The MAX3902 EV kit contains an optical evaluation section.

- 8) Install a photodiode with optical source. For layout configuration refer to Figure 1.
- 9) Connect J15 and J16 to a high-speed 50 Ω oscilloscope. The output seen on the oscilloscope should be an 800mV_{P-P} differential output.
- 10) Connect a voltmeter to the TP13 (STATUS) test point. The output will indicate if the optical connection is successful.

MAX3902 Evaluation Kit

Evaluate: MAX3902

Adjustment and Control Description (see Quick Start first)

COMPONENT	NAME	FUNCTION
JU1, JU4	-	Installing a shunt across JU1 or JU4 (or both) emulates photocurrent at the FILTER pin, which allows MAX3902 to enter the operational mode (STATUS = LOW). Removing shunts from JU1 and JU4 enters the standby mode (STATUS=HIGH).
JU5	-	Used for bypassing the supply filtering if needed.

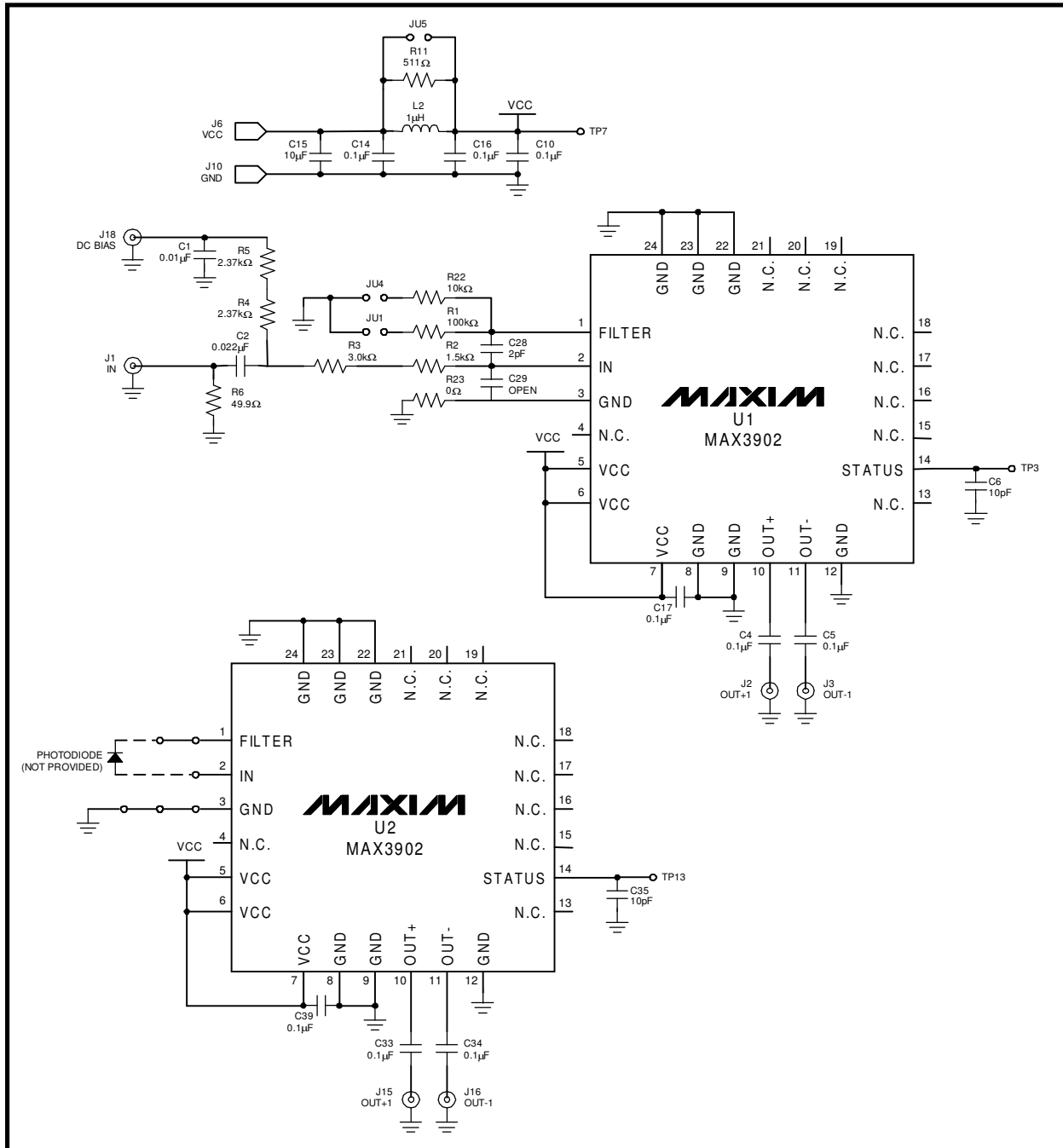

Figure 1. MAX3902 EV Kit Schematic Diagram

MAX3902 Evaluation Kit

Evaluates: MAX3902

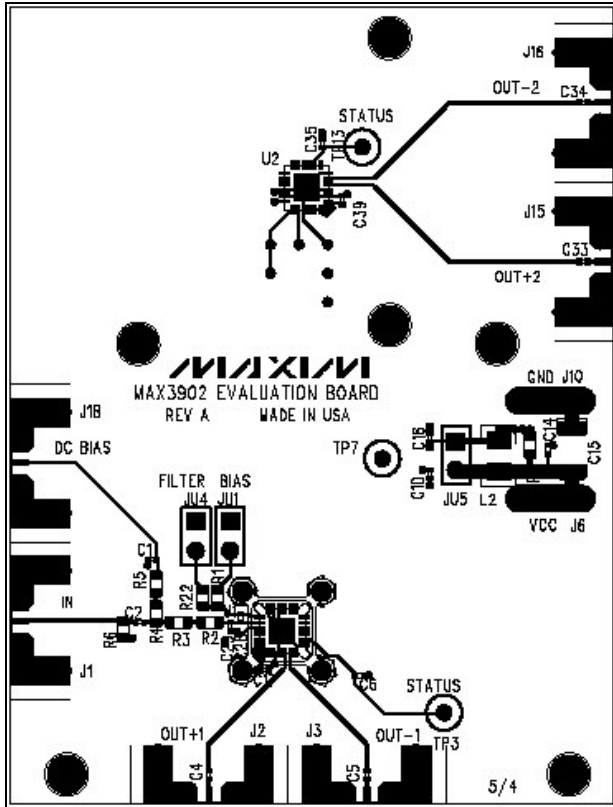

Figure 2. MAX3902 EV Kit Component Placement Guide - Component Side

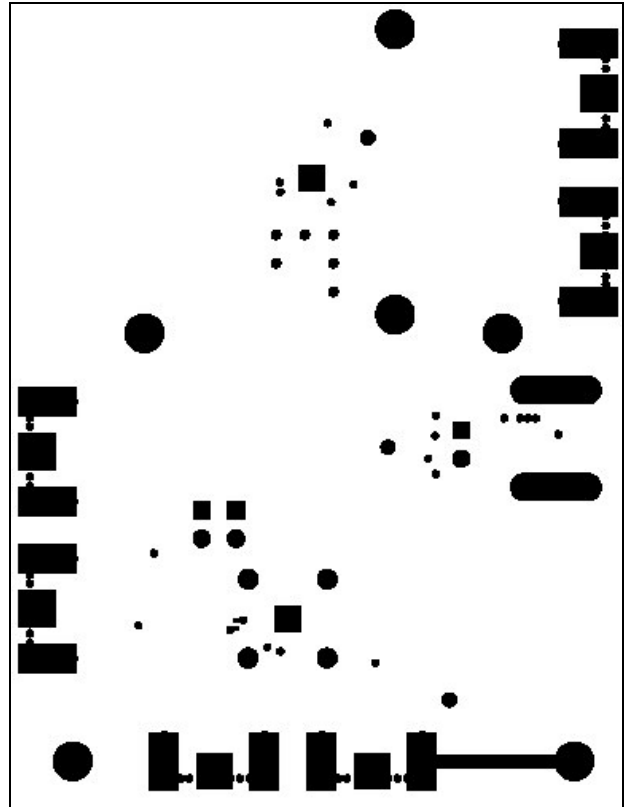

Figure 3. MAX3902 EV Kit PC Board Layout - Solder Side

MAX3902 Evaluation Kit

Evaluate: MAX3902

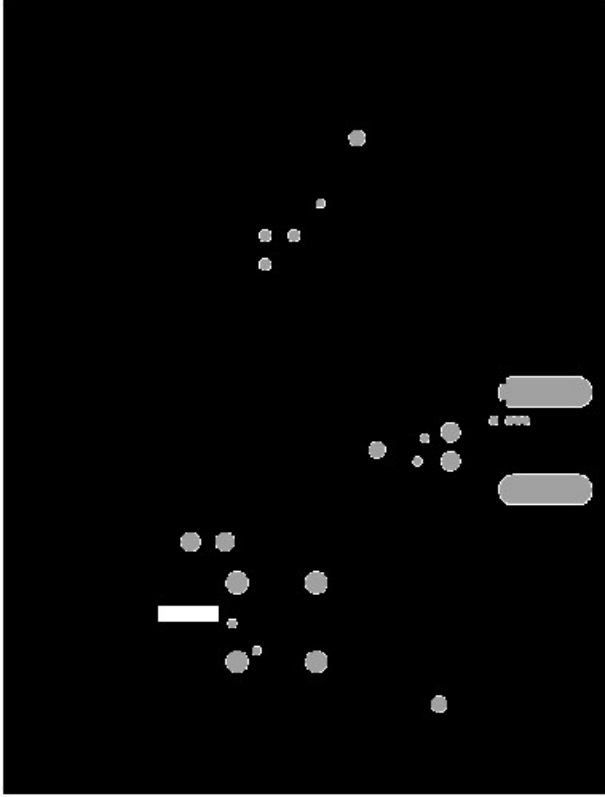

Figure 4. MAX3902 EV Kit PC Board Layout - Ground Plane

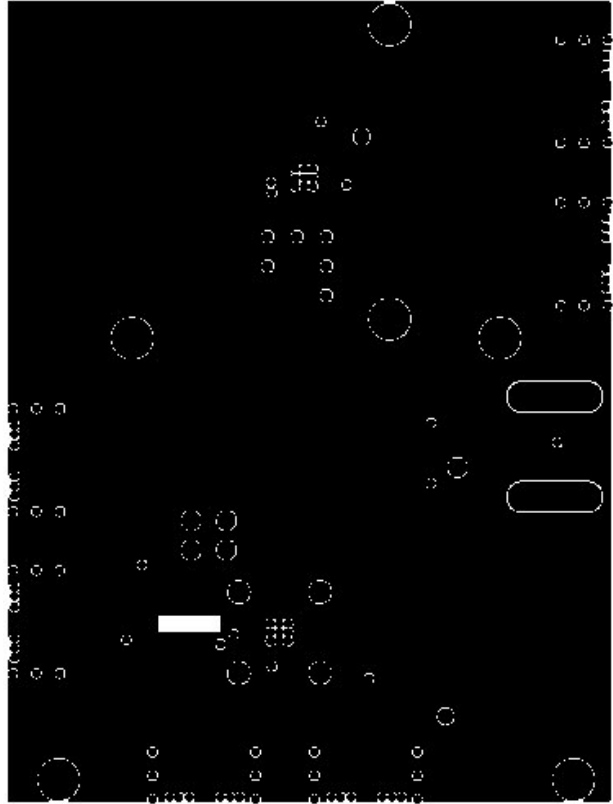

Figure 5. MAX3902 EV Kit PC Board Layout - Power Plane

Maxim cannot assume responsibility for use of any circuitry other than circuitry entirely embodied in a Maxim product. No circuit patent licenses are implied. Maxim reserves the right to change the circuitry and specifications without notice at any time.

4 _____ Maxim Integrated Products, 120 San Gabriel Drive, Sunnyvale, CA 94086 408-737-7600